

---

# 2009 Rules and Regulations

---

## *Official rules for the 2009 ASABE International Quarter Scale Tractor Student Design Competition*

### Design Criteria - Rules

#### 1. Team and Driver Eligibility:

- 1.1. All team members must have been enrolled during at least one semester or one quarter of the design contest school year and have a National ASABE Student Membership.
- 1.2. Team drivers must meet above qualifications and must be enrolled at the school for which they are representing.
- 1.3. The tractor must be designed entirely by the student team members, without direct involvement from outside professionals or faculty. However, as with any design project - faculty, vendor technical support or other professionals may be consulted for advice in selecting and designing specific components. In addition, although not always possible, it is encouraged that the students perform the majority of the fabrication themselves, because this is an important part of the learning process.
- 1.4. A second team per school will be allowed. Schools with two teams must have two significantly different designs; schools that come with multiple teams, with similar tractors, will not be allowed to compete. The school must have two independent teams with different advisors and cannot have members participating on both teams. The first team must register by November 16, 2008. Second teams can apply after that date and competing teams will be decided by lottery. The second main teams will need to purchase their own engines and tires. New schools will have priority over second teams to enter the contest.

#### 2. Size:

- 2.1. Width - no part of the tractor may be wider than 72 inches (1829 mm) maximum.
- 2.2. Length - no part of the tractor may protrude further forward than 96 inches (2438 mm) from the center of the rear axle.
- 2.3. Weight - no tractor may exceed 850 lbs. (386 kg) maximum gross vehicle weight (includes all fluids), without operator and ballast. The tires must be stock, uncut, and in new condition for technical inspections.
- 2.4. Weight classes = 1050 lbs. (477 kg) maximum (class I), 1550 lbs. (703 kg) maximum (class II) All tractors will compete in all classes. Weight classes include weight of tractor, driver, and ballast.

#### 3. Configuration:

- 3.1. Wheelbase changes are not allowed unless they can be accomplished by the driver from the seat.

- 3.2. Unless otherwise noted in a rules section, tractor components are not allowed to be added or removed for all scored events.
- 3.3. Tractors can have a maximum of 4 drive tires. The same number of drive tires must be used throughout the competition.
- 3.4. Tractors can use multiple engines in parallel or independently, but engines cannot be used in series.
- 3.5. All performance pulling events will be performed with an angled chain (no straight-chain pulls).
- 3.6. Hitch heights for the pulls will vary with number of engines. Tractors with a maximum of two engines will be allowed a maximum hitch height of 13 inches. The maximum height is lowered by ½ inch for each additional engine. (i.e. a five-engine tractor will be allowed a maximum hitch height of 11.5 inches.)
- 3.7. No energy storing devices may be used to power the transmission. A clutch assembly will NOT be considered an energy-storing device, if it is reasonably designed.
- 3.8. Components cannot be removed from the tractor to meet weight requirements.
- 3.9. The tractor drivetrain must have the same configuration for all performance and scored events. Only components related to drivetrain ratio changes are allowed to be switched. (i.e. teams will not be allowed to swap a locked differential for an unlocked one or vice versa. Teams cannot swap complete drive axles.)
  - 3.9.1. If a component fails, the team must show the designated competition official that the failed component was replaced with a comparable component.
- 3.10. All tractors must meet the minimum approach and departure angles as depicted in the Appendix, Figure A-8. This includes weights and mid-body chassis clearance while driving on and off the scales or brake test stand.
- 3.11. Any air or fluid suspension system must be used in accordance with the specifications of the manufacturer.
- 3.12. Tractor hitch, frame components, ballast, or any other tractor components cannot contact, support, or interfere with the hook or chain at any time during the pull.

4. **Frame:** Each team must design a fully customized frame. Commercially available lawn and garden tractor chassis or frames are NOT allowed in any form, segmented, modified, reproduced, or otherwise.

ASABE INTERNATIONAL QUARTER-SCALE TRACTOR STUDENT DESIGN COMPETITION  
2009 RULES AND REGULATIONS

5. **Engine:** All tractors must use Briggs & Stratton 16 hp Vanguard engines, Models 303447 or 305447-0079-E1 Engines, factory sealed as delivered. No unauthorized modifications or repairs, internal or external, will be allowed to the engine except as specified in this section. See “*Engine Configuration and Requirements*” (Appendix, Figure A-12) for guidelines the engine must meet to be eligible for competition.

Based upon quantities available and team participation, engines will be supplied by the Competition Organizing Committee. Engines for teams placing first, second, and third will be returned to Briggs & Stratton for disassembly and inspection after the event.

Teams may purchase additional engines. Engines must be purchased directly through Briggs & Stratton. For additional information contact the Rules Chair listed in Section 23.3.

Only Briggs and Stratton accessories can be installed on engines, except for exhaust systems. The Rules Committee must approve any installation of this type of accessory in advance. Contact the Rules Chair listed in Section 23.3. Individual teams are responsible for the purchase of accessories.

- 5.1. **Governor:** Each engine is equipped with a governor that is factory set to 3600 plus/minus 100-rpm “top no-load speed.” The governor idle will be set at 1200 rpm (spring 805454) or 1750 rpm (spring 805453) during the tech inspection (teams can choose either based on their idle spring). Teams are responsible to ensure that their engine is set to – and remains set to – these speeds.

- 5.1.1. Any team found tampering with the governor during the competition will be disqualified. Random inspection of the governor may be conducted at any time during the competition.

- 5.2. **Carburetor:** The carburetor is a “fixed jet” type and must remain stock as delivered. Jets and needles cannot be replaced and all stock adjusters must be used. “Cooling Cans” can be used to cool intake air and fuel (Note: Liquid nitrogen can not be used as a coolant). NO turbo-chargers, superchargers, or other pressurization devices are permitted.

- 5.3. **Fuel Pump:** Teams are not allowed to removed the stock fuel pump or modify any lines connected to it, other than the suction line. If more head pressure is needed prior to the original fuel pump, an additional fuel pump can be used to do this, provided it does not exceed 1.5 psi (10.3 kPa). Engines cannot be modified to get an impulse for an additional vacuum pump. Additionally, if an electric fuel pump is used, it must be wired to shut off when the kill switch is pulled (refer to Section 12).

- 5.4. **Flywheel:** The original engine flywheel must remain intact and cannot be altered in any manner.

5.5. **Exhaust Pipes:**

- 5.5.1. Tuned exhaust systems can be used.
- 5.5.2. Exhaust systems must be guarded per section 2.2.3 of ISO 5395 standard. Heat tape can be used to meet the specification, but not replace it.
- 5.5.3. Exhaust pipes and exhaust gases must be positioned and directed such that they will not affect the tractor

operator, track personnel and/or sled operator. In addition, exhaust discharge cannot be pointed downward or within 45 degrees to the rear of the vehicle.

- 5.5.4. The maximum pass-by noise level with all engines at full throttle and a forward ground speed of  $4 \pm 2$  mph cannot exceed 94 dB(A). Sound measurements will be taken at a distance of 4.0 m (13.1 ft) from the centerline of a 20 m driving path, with the microphone located vertically at 1.2m (3.9 ft). The maximum level will be taken as the peak level at the microphone during the time that the tractor is in the test range. Three runs will be made in each direction, and the final level will be the higher of the average of the two directions. See Appendix Figure A-11 for a diagram of the test setup. Design points for sound will only be awarded for levels below 91 dB(A).

- 5.5.4.1. Tractors must have a means to maintain required ground speed at full engine speed without the use of clutch shims, riding the clutch, etc.

- 5.5.5. Tractors that fail to meet the 94 dB(A) standard have a secondary option to pass the requirement through presentation of results of team testing in written format. This is only a secondary option.

- 5.5.6. The exhaust system used during the sound testing must be used during the entire competition with no addition or removal of any components or accessories during any part of the competition (i.e. chrome covers for static judging).

- 5.6. **Engine Color:** Engine/engine shroud must maintain the original manufacturer’s color scheme and cannot be altered in any manner.

- 5.7. **Ignition System:** Original factory installed ignition system cannot be altered in any manner. However, teams are permitted to substitute factory-installed spark plugs with any brand of choice.

- 5.8. **Fuel Line:** The fuel filter must be within a maximum hose length of 6 inches (152 mm) from the factory installed fuel pump inlet.

- 5.9. **Throttle:** The tractor must have a “Dead-man” throttle, which returns the engine to low idle upon release.

- 5.9.1. The throttle return spring must not be attached to the rotating component of the engine control bracket (see Appendix, Figure A-7).

- 5.10. **Engine PTO:** Tractors must not have bearings installed on either front or rear engine PTO shafts; i.e. no bearing can rotate when engine is disconnected from drivetrain.

6. **Fuel and Lubricants:** Gasoline will be supplied at the competition to ensure equal engine performance. Eighty-seven (87) octane fuel will be used.

- 6.1. Any oil brand that satisfies Briggs & Stratton operator manual recommendations is acceptable.

ASABE INTERNATIONAL QUARTER-SCALE TRACTOR STUDENT DESIGN COMPETITION  
2009 RULES AND REGULATIONS

6.2. Combustible additives/compounds of any form cannot be added to the fuel or lubrication systems.

**7. Fuel System Safety Requirements:**

7.1. One (1) fuel tank per tractor with a max capacity of 3 quarts (2.84L) per engine is permitted. A sight gauge or transparent tank with a 1-quart level mark must be incorporated on the tank/gauge.

7.2. A manual fuel shutoff must be mounted at the tank's outlet or installed inline between the fuel tank and the fuel pump. The shutoff must be accessible from the outside of the tractor without having to move or remove any tractor components, including hood, and without having to use tools (i.e. hand operated).

7.3. A dedicated drain line, with quick and easy access, must be incorporated into the fuel system to allow draining of the fuel. The drain line must be accessible from outside the tractor, without the removal of shielding, and must drain to the ground without contacting any other tractor components.

7.4. Fuel tank cannot be mounted in the same sealed compartment with any battery. Minimum distance between fuel tank and battery is 24 inches (610 mm). Fuel tank and battery mounting positions must be physically located in separate well-ventilated compartments.

7.5. Fuel tank must have a minimum opening of 1.25 inches (32 mm) diameter and be equipped with a vented, no-spill fuel cap that will prevent excessive fuel leakage (i.e. more than a drip) when inverted.

7.6. Fuel tank must have easy access to refuel with the Briggs and Stratton Smart-Fil fuel can.

**8. Battery:**

8.1. Tractor designs are limited to a single battery. Battery must be capable of starting the vehicle consistently. Tractors will not be allowed to have "jump start" once hooked to the sled or during any scored event. Manufacturer label with specifications must be intact on batteries.

8.2. Battery must be rigidly mounted on the tractor frame/chassis in a well-ventilated compartment. (The use of rubber or elastic straps to secure batteries will not be permitted) Mounting location must be separate from the fuel tank location (refer to Section 7.4).

8.3. The positive battery terminal and all positive terminals throughout the machine must be completely covered to avoid inadvertent contact.

**9. Clutches:** All clutch assemblies must rotate at engine speed or slower. A power-disengaging clutch, operable from the operator's station by the driver, must be used in order to disconnect the tractor power in the event of an emergency, regardless of drivetrain configuration. This clutch must be activated by a pedal, lever, or by disengaging the throttle.

**10. Service Brakes:** Tractors must have working service brakes.

10.1. A dynamic brake will NOT be allowed unless it is in conjunction with working service brake(s).

10.2. Outboard brakes (outside of final drives, U-Joints, and CV joints) are required on all wheels on the rear-most drive axle.

10.3. Service brakes will be tested during the technical inspection session. The tractor will be ballasted to 1550 lbs. (703 kg) with an operator sitting in the seat who will apply the brakes. The tractor will be raised on an incline of 20° and will need to fully lock the brake tires to pass the test. Tractors must hold at the full inclination and will not be permitted to slide at any point during the brake test.

**11. Tires:** All driven tires must be Firestone 26 x 12.00 – 12 Flotation 23° tires with a maximum wheel (rim) width of 12 inches (305 mm). Based upon quantities available and team participation, tires will be supplied by the Competition Organizing Committee. Contact the Rules Chair in Section 23.3 if tires or more information is needed.

11.1. Tires can be conditioned, cut, and sharpened for all performance events. However, sidewalls must remain unaltered.

11.2. Tires cannot be recapped.

11.3. No tracks, chains, studs or paddles.

**12. Kill Switch:** All tractors must have a working kill-switch that shuts off the ignition and electric fuel pump (if one is installed) in the event of the tractor becoming detached from the sled, as shown in the Appendix, Figure A-4.

12.1. The kill switch must be located in the center of the rear of the tractor and have a ½-inch (13 mm) hole to which a tether cord can hook.

12.2. The kill switch must be positioned 13 - 15 inches (330 - 381 mm) above the tractor hitch/hook point of the sled chain.

12.3. A 5-inch (127 mm) square opening around the kill switch is required to allow for unobstructed hookup of the tether.

12.4. Kill switches cannot be mounted to the hitch. Mounting hardware must be independent of the hitch such that the kill switch will remain intact in the event of hitch failure.

**13. Wheelie Bars:** All tractors must have two wheelie bars and two bumper-bars. Wheelie bar designs can use either wheels or pads.

13.1. The center of the wheel or pad on the wheelie bars cannot be less than 5 inches (127 mm) behind the rear of rear tires, and the bottom of the wheel or pad cannot be higher than 4 inches (102 mm) above the ground (see Appendix, Figure A-1).

13.2. A minimum effective area of 18 total square inches (116 cm<sup>2</sup>) or no less than 9 square inches (58 cm<sup>2</sup>) per pad is required if pads are used.

13.3. A minimum effective diameter of 4 inches (102 mm) and a minimum effective width of 2 inches (51 mm) per wheel is required if wheels are used.

13.4. Wheelie bars must be rigid in all directions and able to support the full weight of the rear of the tractor with no deflection on one (1) wheel or pad regardless of

ASABE INTERNATIONAL QUARTER-SCALE TRACTOR STUDENT DESIGN COMPETITION  
2009 RULES AND REGULATIONS

configuration with the operator in place and ballasted to meet brake test requirement (see Appendix, Figure A-6).

- 13.5. Bumper-bars must protect wheelie pads/wheels from inadvertent sled contact. Bumper bars must be the furthest point rearward on the tractor. Bumper-bars must be rigidly attached to the back of the wheelie bars and consist of a 6-inch (152 mm) vertical member that will prevent the sled from “riding up” the wheelie bars. Bumper-bars must be designed as individual bars on each wheelie bar, as shown in the Appendix, Figure A-1.
- 14. Hitch:** The hitch can be adjustable. However, the hitch must have a means to lock it rigidly in all directions and cannot move in reference to other tractor components for the pulling event.
- 14.1. Hitch must be fabricated from low carbon steel plate having a thickness of ½ to ¾-inch (13 to 19 mm).
- 14.2. Hitch must incorporate a 1-3/4 inch (45 mm) minimum diameter hole or opening (See Appendix, Figure A-2).
- 14.3. A minimum of SAE Grade 5 or Metric Grade M8.8 fasteners can be used for attaching the hitch.
- 14.4. All retaining nuts must be locking-nuts with a minimum of two threads showing above the nut.
- 14.5. Hitch must be structurally independent from the wheelie bars.
- 14.6. Pulling point may not be more than ¾-inch (19 mm) from back edge of hitching device (See Appendix, Figure A-2), parallel to, and not more than height specified in Rule 3.4 above the ground at all times (i.e. rear suspension at maximum height and front suspension at minimum height). This will be measured at the hook point on the top of the hitch, with the driver in the seat. *Active suspension systems must be able to reach its extremes on the scales for hitch height checks prior to each pull.*
- 14.7. Hook point must allow for easy hooking and unhooking of the chain with a minimum space of 5 inches (127 mm) horizontally and 5 inches (127 mm) vertically (See Appendix, Figure A-4)
- 14.8. The hitch hook point must be on or rearward of the centerline of the rear axle.
- 15. Shielding and Guards:** All chains, gears, pulleys, and rotating parts must be shielded to protect hands and fingers from entering and being injured at all times (Refer to Appendix, Figure A-3 for shielding illustration). ASABE, SAE, ANSI, ISO, and OPEI have developed numerous safety and shielding standards for agricultural equipment. Minimum shielding requirements must meet or exceed ASAE Standard S493, “Guarding for Agricultural Equipment.” Specific shielding requirements are as follows:
- 15.1. Minimum thickness for shielding covering the peripheral area of rotating drivetrain parts must be 1/8-inch (3 mm) thick for low carbon steel, or ¼-inch (6 mm) thick for aluminum. The sides of guards and shields may be covered using expanded metal, provided it meets or exceeds ASAE Standard S493.

15.2. All parts that rotate while the tractor is stationary and that the operator can come into contact with during normal starting and operation must be totally enclosed to safeguard against entanglement. The material type and thickness is open, as long as it prevents inadvertent contact from the rotating part(s).

**15.3. Clutch Shielding:**

15.3.1. Clutches must be fully enclosed. Shielding must be a minimum of 1/8-inch (3 mm) thick low carbon steel or 1/4 inch (6 mm) thick aluminum. No expanded metal is allowed. Note: Belts operating as a clutch must be shielded as a clutch.

15.3.2. If clutch directly drives other components (i.e. sprocket, pulley, or sheave) within the same housing or compartment, the entire shield must be of the material thickness and type per 15.1. Shielding around the clutch with openings for a belt/chain will not be allowed.

**15.4. Driveshaft Shielding:** Driveshafts, regardless of length, must have safety loops that will secure the driveshaft to prevent tractor damage and endangerment of the driver if a u-joint or other coupler were to break or the driveshaft were to come loose while still turning. Driveshafts (universal joints included) longer than 18 inches (457 mm) will require multiple loops.

15.5. Engine shields that are stock for the engine must remain intact, including the flywheel rotating screen.

15.6. If the flywheel screen is the furthest point forward on the tractor, a bumper must be incorporated to prevent contact between the rotating screen and stationary objects encountered during tractor movement (i.e. posts or other objects during tractor maneuvering in tight areas).

15.7. All Shields must be securely fastened to the tractor frame or associated chassis members. The use of at least 1/4-inch (6 mm) diameter SAE Grade 5 or Metric Grade M8.8 hardware will be required to fasten all shields. Bungee strap type fasteners are not allowed. Tools must be required to remove the shields. (i.e. no wing nuts, thumb screws, etc.)

**16. OEM Shielding:** Tractor designs can use original equipment stock shielding for components if the manufacturer designed the shield for the specified component for the intended application. Teams are required to contact manufacturers and discuss proposed application, mounting arrangement, and ASABE rule specifications. Teams must supply manufacturer with appropriate design specifications/drawings and documentation to make sure shield is adequate and receive written authorization to use the shield in the tractor design.

16.1. Teams must submit written manufacturing authorization by March 31, 2009 for OEM shields. This documentation must be submitted to the person named in Section 23.3. The shield will not be allowed at the competition, if it is not submitted. Note: Documentation will not be accepted after the deadline.

16.2. OEM shielding must be verified for safety judges. Manufacturer literature or specifications must be presented to

ASABE INTERNATIONAL QUARTER-SCALE TRACTOR STUDENT DESIGN COMPETITION  
2009 RULES AND REGULATIONS

technical inspection judges to verify shielding meets Competition Rules.

- 16.3. Shield must be properly mounted/installed and cannot be modified (i.e. drilling holes to lighten) in any manner that would weaken the original design

**17. Steering:** Tractor designs must incorporate traditional front axle steering mechanisms. *Any tractors with a steering system ruled unsafe by the rules committee will not be allowed to compete in performance events.*

- 17.1. All teams that use a steering system that is not fully mechanical (i.e. electric, hydraulic, etc.) must submit documentation that identifies the fail-safe modes (i.e. what would happen to the steering if loss of control loop occurs during operation) by March 31, 2009 to the person named in Section 23.3.
- 17.2. If the tractor is equipped with a drive by wire type set up (i.e. no steering wheel), a grab handle must be positioned so that the driver can use it as support when driving the vehicle.
- 17.3. No rear or mid wheel steering.
- 17.4. No skid steering (i.e. powering wheels in opposite directions).
- 17.5. No articulated machines.
- 17.6. No narrow front ends are allowed (i.e. tricycle front ends). All tires must partially track within the rear wheels when the tractor is driven straight forward. The front tire minimum track width is 24 inches (610 mm) on center.
- 17.7. Hardware requirements related to the steering system include all mechanical components from the steering wheel to the wheels being steered.
- 17.7.1. Only SAE Grade 5 or Metric Grade M8.8 fasteners can be used for attaching steering components. SAE Grade 8 fasteners are not acceptable due to safety considerations (Grade 8 will completely fail whereas Grade 5 will bend).
- 17.7.2. All retaining nuts must be castle or locking nuts with a minimum of 2 threads showing. If a screw is used in a threaded hole it must have a spring lock washer.

**18. Body Components:** Tractor designs must include functional footrests, and fenders

- 18.1. The hood cannot be used as a shield or as a guard. The hood must incorporate a quick detachable design for access to the governor linkage for engine technical inspection (i.e. no bolt on hoods, sturdy quick release latches are acceptable).
- 18.2. Fenders must be functional, sturdy, and rigidly mounted to protect the driver from any driven wheels (front or rear). Fenders must cover at least two-thirds the width of all driven tires and include inner fender walls to protect the operator from inadvertent contact with tires. Fenders must incorporate a minimum radial coverage of 90 degrees and positioned so they best protect the operator. Fenders must have a minimum clearance of 1.2 inches (30 mm) between the fender and tire/rim peripheral area and a minimum clearance

of 0.6 inches (15 mm) between the fender and the inside of the tire.

- 18.2.1. Fenders must not deflect more than 0.5 inches (12.7 mm) towards the tire at the outermost edge when a 5-lb (2.27-kg) weight is placed on the fender over the centerline of the outermost tire.

- 18.3. Operator footrests must be sturdy and rigidly mounted to the tractor frame/chassis. Footrests must protect the operator from inadvertent contact with all tires and the ground.

**19. Hydraulics:**

- 19.1. The maximum system working pressure allowed for hydraulic systems on a tractor is 4,000 + 50 psi (276 + 3.4 bar). The maximum pressure of any system must be equal to or less than the lowest intermittent pressure rating of any component in the system.
- 19.2. Hydraulic hoses, tubes, and fittings must be rated for the corresponding system working pressure. Hoses need to be clearly marked with the OEM working pressure rating. Pipe thread fittings and hose clamps are only allowed on pump suction lines and tank sight gages.
- 19.3. Custom hydraulic system components, regardless of system pressure, may not be welded or braised as a method of joining, unless used in the pump suction lines or reservoir.
- 19.4. A test port, which is easily accessible, must be present at the high-pressure side of any pump and in any other system running a different working pressure (i.e. a pilot circuit). Test ports must remain on the tractor at all times and meet SAE Standard J1502.
- 19.4.1. Hydraulic steering systems that do not receive powered pump flow are not required to have test ports in the steering system. If charge pump flow or any other powered flow is used to supply the steering circuit, test ports are required in the steering circuit.
- 19.5. Tractor design must incorporate a means (i.e. needle valves, solenoid valves, etc) for all system pressures (detailed in rule 19.3) to be tested without having to install external hardware into the systems during technical inspection. All components necessary for the pressure checking must remain on the tractor at all times.
- 19.6. Hydraulic lines must be located so they are not subject to damage from debris, from installing or removing adjacent components or from operator contact when mounting or dismantling the operator station.
- 19.7. Hydraulic lines must not rub any sharp edges. Hose guarding is required where damage may result. ALL exposed hoses during normal operation must be completely covered with a protective hose covering or continuous shielding.
- 19.8. Hydraulic lines must have a mechanism (clip/clamp intended for hydraulic use) to guide multiple hoses through their range of motion to prevent fouling (rubbing) or abrasive action.
- 19.9. Fasteners for hydraulic lines must be designed to withstand the line movement caused by pressure fluctuations in the system. Clips or clamps must be heavy enough to securely

fasten the lines. Fasteners must not have sharp edges that could damage the lines.

19.10. Hydraulic hoses must not be routed in high ambient temperature areas without proper protective shielding.

19.11. If a hydraulic system is used on the tractor, a hydraulic system schematic (see Appendix, Figure A-9) and component list (see Appendix, Figure A-10) with factory specified pressure ratings must be submitted to the person named in Section 23.3 by March 31, 2009. If not received by that time, your team will not be eligible for "First Time Through" award for tech inspections. The schematic must include system components (tank, pumps, valves, motors, relief valves, check valves, test ports, etc.) drawn with standard symbols (refer to ISO 1219), as well as specifications pertaining to those components that dictate system operating characteristics (relief valve setting, flow from a pump, check valve ratings, orifice diameters, pump speed ratio, etc.). Any changes after the due date must be submitted to the person named above, immediately.

## 20. Safety Design Requirements:

20.1. All tractors are required to have a dry 2-lb. fire extinguisher (BC rating with functional gauge) mounted securely on the vehicle at all times. It must be accessible in case of fire and remain in its original mount and location throughout the event (i.e. the fire extinguisher cannot be used or repositioned for ballast).

20.2. A clutch lever switch and seat switch are required to prevent starting any engine unless the operator is in the operator's position in the seat. In the case of CVT's, hydraulic, hydrostatic, or electric drives, the service brake must be depressed.

20.3. A positive powertrain disconnect must be incorporated into all tractor designs. The positive disconnect must be located between the engine PTO and the drivetrain. This positive disconnect may be a sliding coupler, Lovejoy coupler, Dodge coupler, or bare shaft. Couplers cannot exceed 4 inches (102 mm) in diameter. In addition, no disengaged clutches will count as quick-disconnects. Components left on the engine shaft during engine tech inspections must be shielded.

20.3.1. Each engine must be able to be disconnected in less than 2 minutes by one person and reconnected in less than 2 minutes by one person. This includes the removal and installation of any shields, guards, and/or body components. *Operation of the disconnect(s) will be checked and timed during tech inspections.*

20.4. Sturdy seat with a minimum 4-inch (102 mm) tall backrest that will support the driver's lower back is required. Seat pan will be restricted to 22 inches (559 mm) maximum in length and 20 inches (508 mm) maximum in width. Seat and support must be adequate to maintain the operator's weight without any major deflection or failure during safe operation of vehicle. Pan-type seats are not permitted. Seats must be rigidly mounted and must not be able to move in any direction relative to the frame during operation. The back of the seat must not extend beyond the back of the rear tires.

20.5. Operator safety must be considered in the design and layout of all controls and components. Reference SAE Standard J833 to ensure that tractor designs safeguard the operator from injury due to contact with any components including tires during normal operation and during conditions of instability (wheel hop, front-end rare-ups, etc.). Designs must insure that no part of the operator can contact exhaust pipe(s) when leaning forward or back.

20.6. Any fastening hardware that is required to meet a specific grade must have standard head markings as indicated in the Appendix, Figure A-5.

20.7. Electrical components must follow the manufacturers recommended safety precautions. Original manufacturer's safety document must be available at time of technical inspections.

## 21. Ballast:

21.1. The rear weights must not protrude more than 6 inches (152 mm) past the rear-most point of the rear tires.

21.2. Only ballast can be added and removed between pulls. Ballast is an object whose sole purpose is to be used to balance the tractor. Examples of ballast include weights, driver, and weight brackets. Examples of non-ballast items include hoods, front axles, body components, drivetrain components, and four-wheel drive components. The same number of wheels must remain on the tractor; however, tire/rim combinations can be changed to accommodate different track conditions.

## 22. Data Acquisition:

22.1. Data acquisition and controllers are allowed in the tractor design but may not affect or alter any portion of the engine performance.

22.2. Power for sensors or data acquisition devices may be supplied by a separate battery source.

22.3. Power for controller motors or similar equipment must be supplied by the tractor's battery (refer to Section 8).

## 23. Miscellaneous:

23.1. National Contest Sponsor Decals will be supplied at the event and must be used. All teams must display the logo of the competition, major sponsors and their school's name and number on at least three sides of the tractor. The team name must be legible and printed in letters that are at least 2 inches tall. The team number must be legible and printed in numbers that are at least 4 inches tall. All decals must be in place in order to complete technical inspection. Sponsor decals must not be modified or trimmed in any way. Teams are responsible for making sure that all logos are displayed during all pulls. Failure to comply will result in team DISQUALIFICATION. Specific decal sizes and quantities will be listed in the Competition Handbook or other ASABE mailing (The number and size of decals are subject to change and will be finalized closer to the competition).

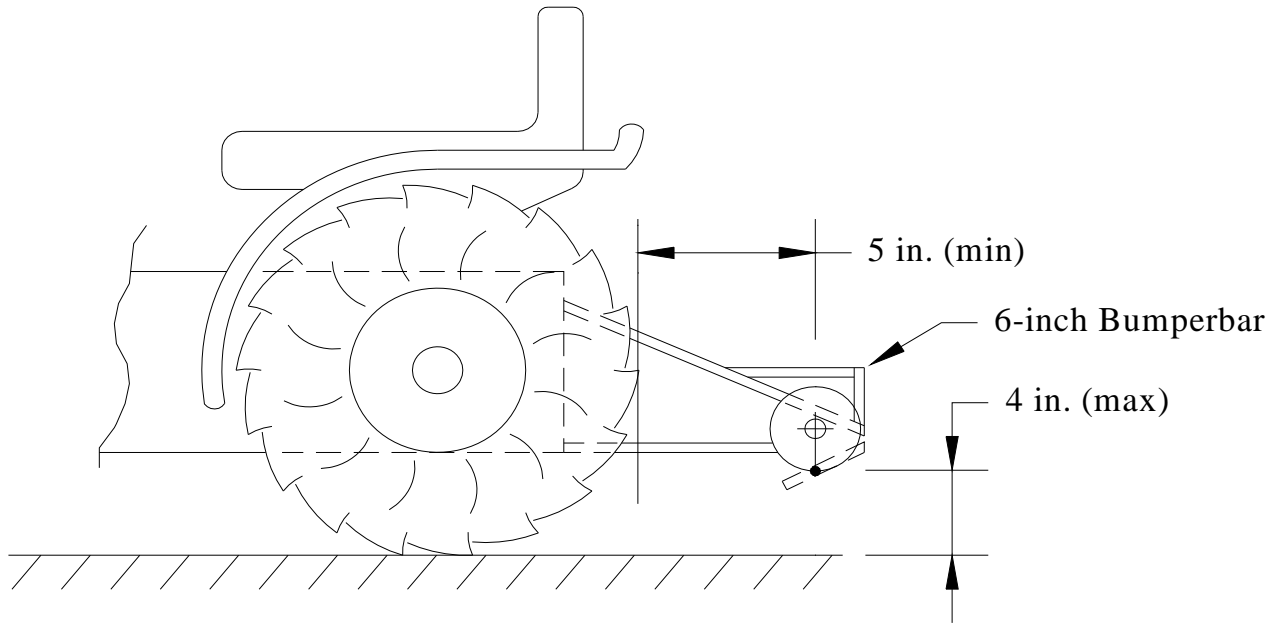
23.2. If a team withdraws from the competition, they must return the engine and tires to the Competition Organizing

ASABE INTERNATIONAL QUARTER-SCALE TRACTOR STUDENT DESIGN COMPETITION  
2009 RULES AND REGULATIONS

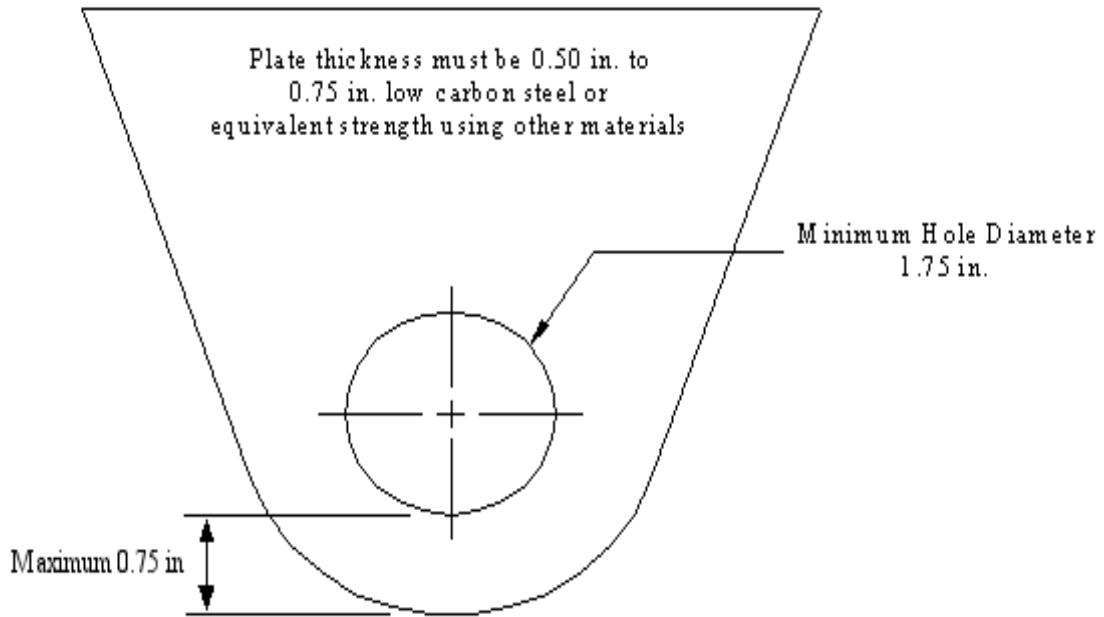
Committee. For this, please contact the Competition Rules  
Chair listed in Section 23.3

23.3. For all questions about the rules, engine related issues, or  
how to interpret the rules, contact the Competition Rules  
Chair: Jim Kopriva, james.kopriva@agcocorp.com

**Appendix – (All figures not to scale)**



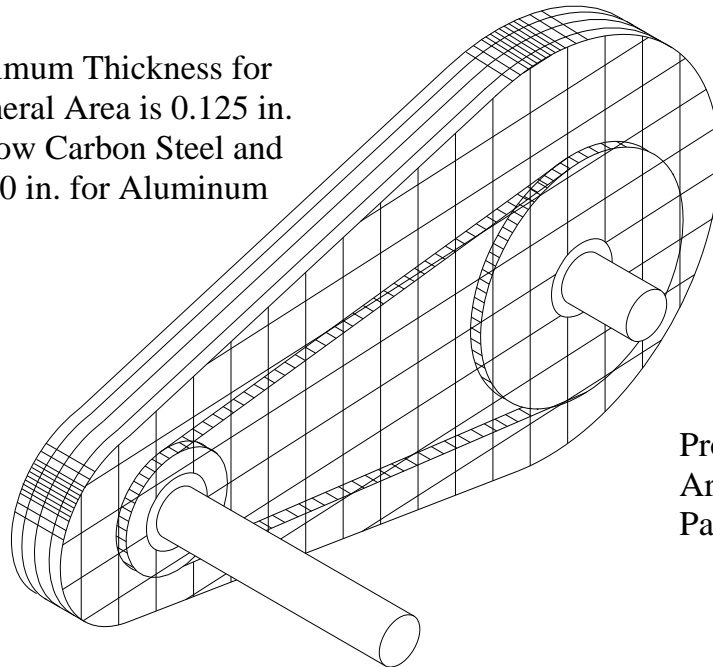
*Figure A-1 Spacing of Wheelie Bar Unit on Tractor (Wheels or Pads)*



*Figure A-2 Minimum Requirements of the Hitch Design*

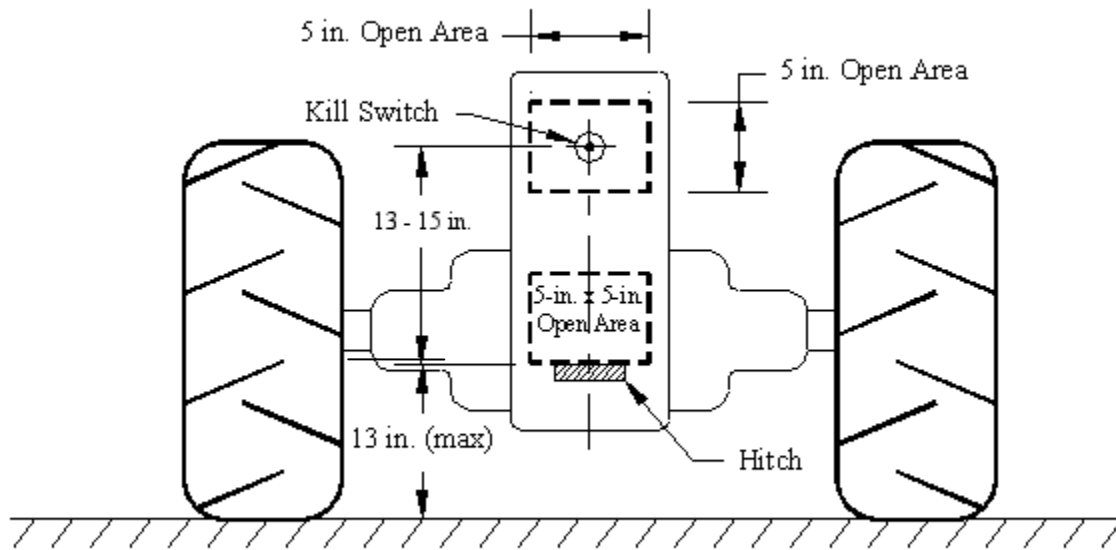
## Appendix

Minimum Thickness for Peripheral Area is 0.125 in. for Low Carbon Steel and 0.250 in. for Aluminum



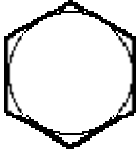

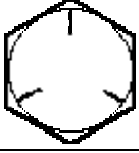

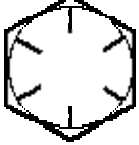

Proper Shielding Around All Moving Parts is Required

*Figure A-3 Example of Proper Shielding for Moving Parts*

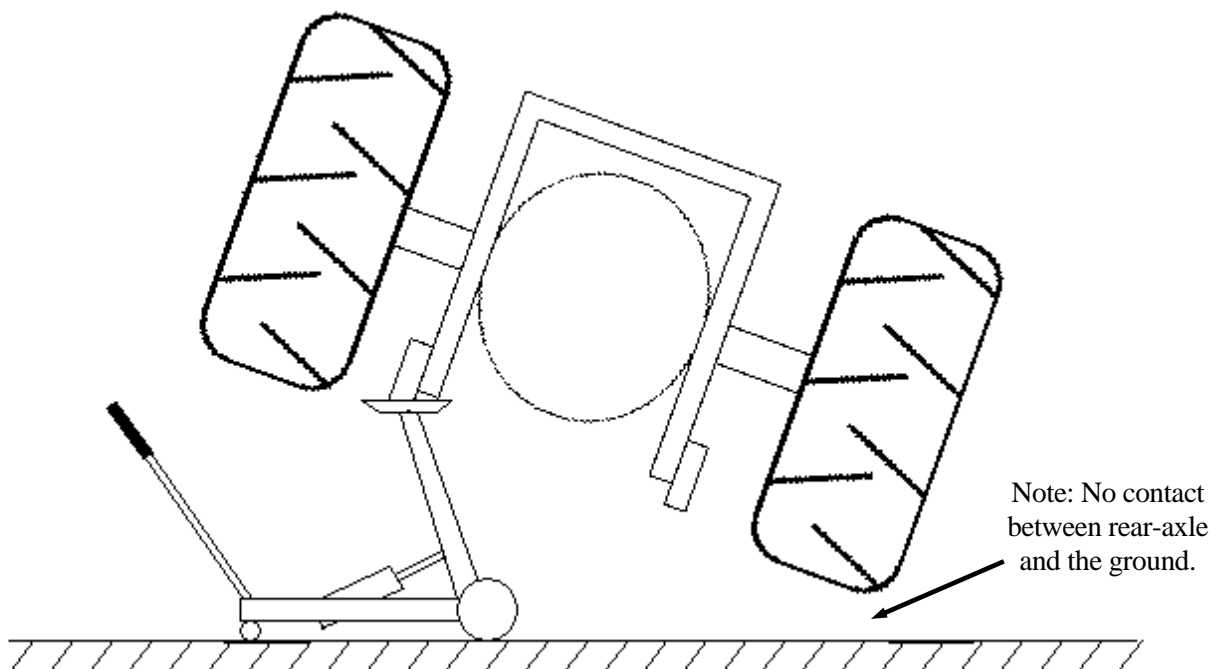


**Figure A-4 Hitch and Kill Switch Specifications**

## Appendix

SAE Grade 2		Metric Grade 5.8	
SAE Grade 5		Metric Grade 8.8	
SAE Grade 8		Metric Grade 10.9	

*Figure A-5 Bolt Head Markings*



*Figure A-6 Wheelie Bar Test*

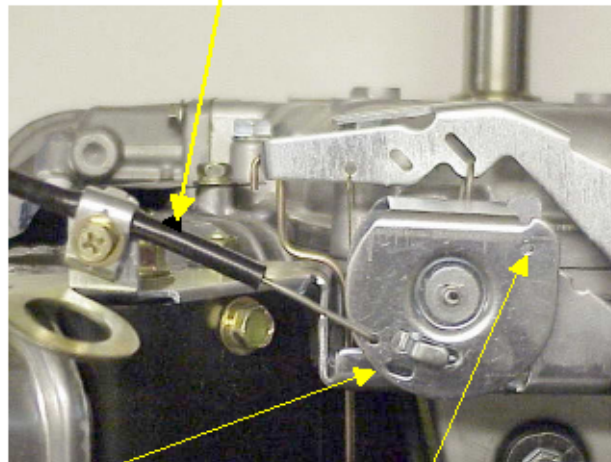
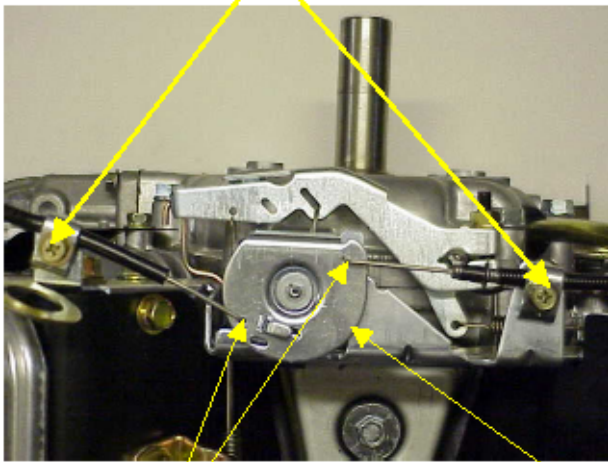
## Appendix

### THROTTLE CABLE and RETURN SPRING INSTALLATION

- 1) The throttle cable can be attached to the engine from either side. On one side the cable will be in the pull mode and on the other side it will be in the push mode.
- 2) In the typical application only one of the rotating component holes will be used. **YOU CANNOT ATTACH YOUR RETURN SPRING TO THE UNUSED HOLE OR ANY OTHER LOCATION ON THE ROTATING COMPONENT.**
- 3) The return spring must be located before the cable connection at the rotating component. There are to be no spring loads on the rotating component.

CABLE SHEATH ANCHOR POINTS

CABLE ATTACHED IN PULL MODE



CABLE ATTACHMENT POINTS

ROTATING COMPONENT

ROTATING COMPONENT UNUSED HOLE

*Figure A-7 Throttle Cable and Return Spring Installation*

Tractor must have clearance with the brake test stand/scales while driving on and off (including all components such as tractor weights and mid-frame clearance).



*Figure A-8 Approach and Departure Requirements*

# Appendix

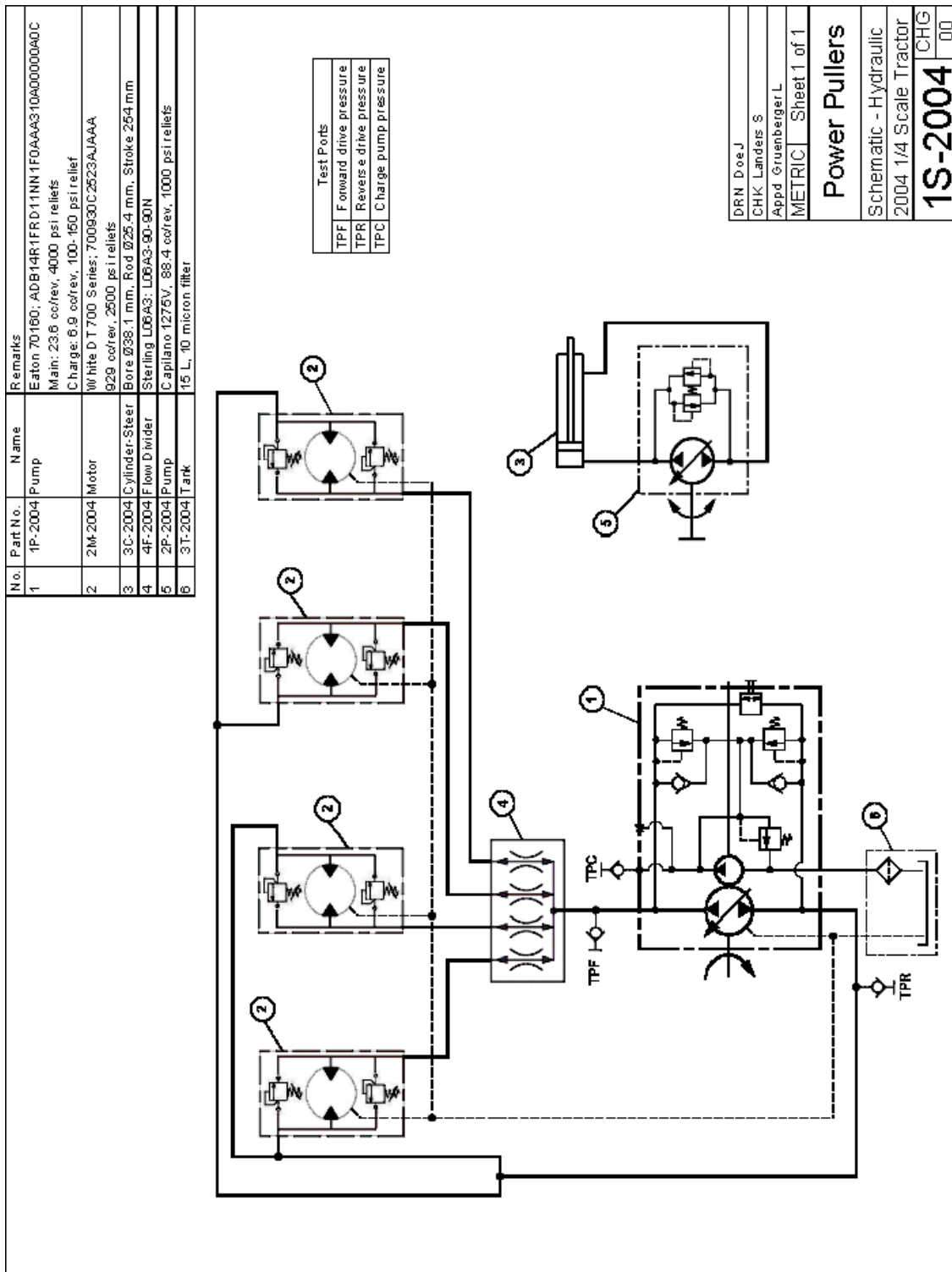


Figure A-9 Example Hydraulic Schematic

## Appendix

### Hydraulic Component List

Teams utilizing a hydraulic system on their tractor must supply a component list document (i.e. Microsoft Word), separate from the schematic, which contains the following information for all major components (pumps, motors, valves, flow dividers, cylinders, oil coolers, etc.):

Manufacturer and Model

Order Code

Manufacturer Pressure Ratings - Continuous, Intermittent, Peak (pumps, motors, etc.); Maximum (valves, flow dividers, etc.)

Pressure reducing valve settings (if the component contains any)

Pump flow at high idle (engine speed of 3600 rpm; pumps only)

Maximum Flow Rating (valves, flow dividers, motors, etc.)

Maximum Manufacturer's Speed (pumps and motors)

#### Examples:

Eaton Model 70160 Manually Controlled, Closed-loop, Variable Displacement, Piston Pump

Order Code: ADB14R1FRD11HH1F0AAA310A00000A0C

Manufacturer Pressure Ratings: Continuous - 3000 PSI

Max Intermittent - 5000 PSI

Reliefs Set At: Drive Pump - Two at 3000 PSI (one for each flow direction)

Charge Pump - 100-150 PSI

Pump Flow at HI: Drive Pump - 21.6 gpm

Charge Pump - 7.2 gpm

Maximum Manufacturer's Speed: 3600 rpm

Sterling Model L06A3 Spool type Flow Divider with Sterling Model LB10 Line Body

Order Code: L06A3-60-60-N

Maximum Manufacturer Pressure Rating: 6000 PSI direct

400 PSI max flow pressure drop

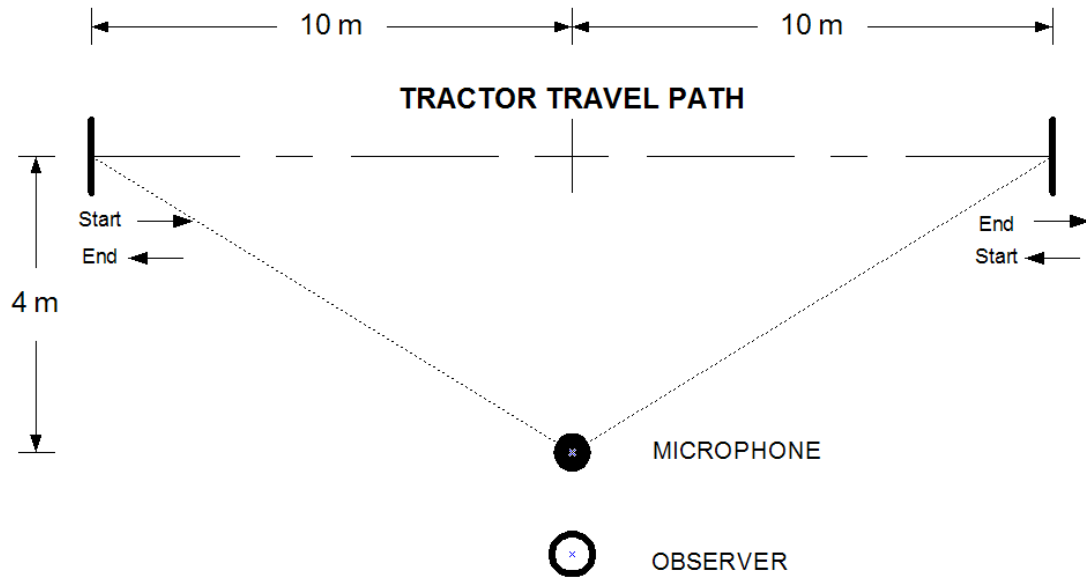
Maximum Flow Rating: 23.8 gpm

Order Code: LB10785S

Maximum Manufacturer Pressure Rating: 6000 PSI

*Figure A-10 Component List Requirements and Examples*

## Appendix



*Figure A-11 Tractor Noise Test Setup*

## Appendix

### Engine Configuration and Requirements

During the past couple years, it has been noticed by the committee that some engines on tractors at the competition have had wrong, damaged, or missing parts. This list below is a guideline that engines must comply with to compete at the competition. Use this guideline to inspect your engine and make the necessary changes. All tractors must use Briggs & Stratton 16 hp Vanguard engines, Models 303447 or 305447-0079-E1 Engines, factory sealed as delivered.

1. If the speed control bracket on your engine does not look exactly like the one pictured in Figure A-7 of the 2009 Rules due to adjustments made or any other reason, it needs to be replaced. If any adjustments were made to the speed control bracket utilizing any tool other than Briggs & Stratton Part # 19480, your speed control bracket needs to be replaced. Replacement of the speed control bracket needs to be completed prior to the 2009 competition.
2. All engines must have Briggs & Stratton 40 micron fuel filter, Part # 691035 (filter is opaque in color).
3. Air cleaner must have Briggs & Stratton element, Part # 394018 and foam pre-cleaner, Part # 272490.
4. All engines must have Briggs & Stratton engine oil filter, Part # 492932 (black exterior).
5. There are three allowed positions for the oil filter: vertical (original engine configuration), horizontal, and remote. If it is necessary to use either the horizontal or remote configuration, Briggs & Stratton parts must be used.
6. All screws required for retaining blower housing must be in place.
7. All engine components, that were on the engine when delivered, must be in place. This includes the black panel in front of the carburetor.
8. Engines originally equipped with a fuel shut-off solenoid must have it in place and functioning. These include:

Engine Model	Solenoid from Factory
303447-0386-01	No
303447-1026-E1	No
303447-1075-E1	No
303447-1079-E1	Yes
303447-1170-A1	No
303447-1379-E1	Yes
303447-1441-E1	Yes
305447-0079-E1	Yes

9. Tractor designs may incorporate a flywheel end stub shaft and rotating screen with a center hole. If a stub shaft was used in the past but not being used currently, then a Briggs & Stratton flywheel screen without the center hole must be used.

*Figure A-12 Engine Configuration and Requirements*