



Challenges and Benefits of ISO11783 Standardization



Robert Waggoner

AGCO

10 February 2009

Topics

ISOBUS – A Brief Review

Benefits of ISO11783 Standardization

Potential Engineering Challenges

Next steps for ISO11783

ISOBUS – A Brief Review

What is “ISOBUS”?

Implementation of the ISO 11783 international standard, which specifies a method of interoperability between electronics systems on agricultural and forestry equipment.

ISOBUS – A Brief Review

What is the ISO 11783 Standard?

ISO 11783 Specifies:

- ✓ physical characteristics
- ✓ serial data network (CAN 2.0B) for control and communications
- ✓ minimum functionality of certain devices on the network.
- ✓ data handling and file transfer

ISOBUS – A Brief Review

What is the ISO 11783 Standard?

- ✓ Physical Characteristics

Tractor/implement interface connector

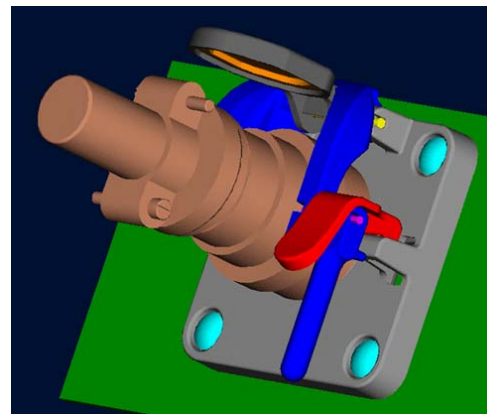
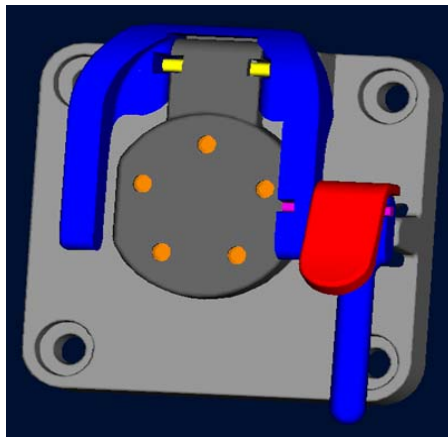

ISOBUS – A Brief Review

What is the ISO 11783 Standard?

✓ Physical Characteristics

CAN bus electrical characteristics:

- Type: Unshielded Twisted Quad Cable
- Characteristic Impedance: 75Ω (Nominal)
- Conductors: 0.5mm^2 (20ga) x 19 Strands
- Size: < 8.5mm Diameter
- Yellow - CAN_H
- Green - CAN_L
- Red - Terminating Circuit PWR
- Black - Terminating Circuit GND



ISOBUS – A Brief Review

What is the ISO 11783 Standard?

✓ Physical Characteristics

Terminating Bias

- Provide 2.5v Bias to CAN transmission lines
- provide the 75 ohm Characteristic Impedance
- each end of the CAN network but NOT inside an ECU

ISOBUS – A Brief Review

What is the ISO 11783 Standard?

✓ Physical Characteristics

Bus length and geometry

- Maximum Segment Length (L): 40 m
- Maximum Drop Length (S): 0.3 m
- Minimum Node Separation (d): 0.1 m

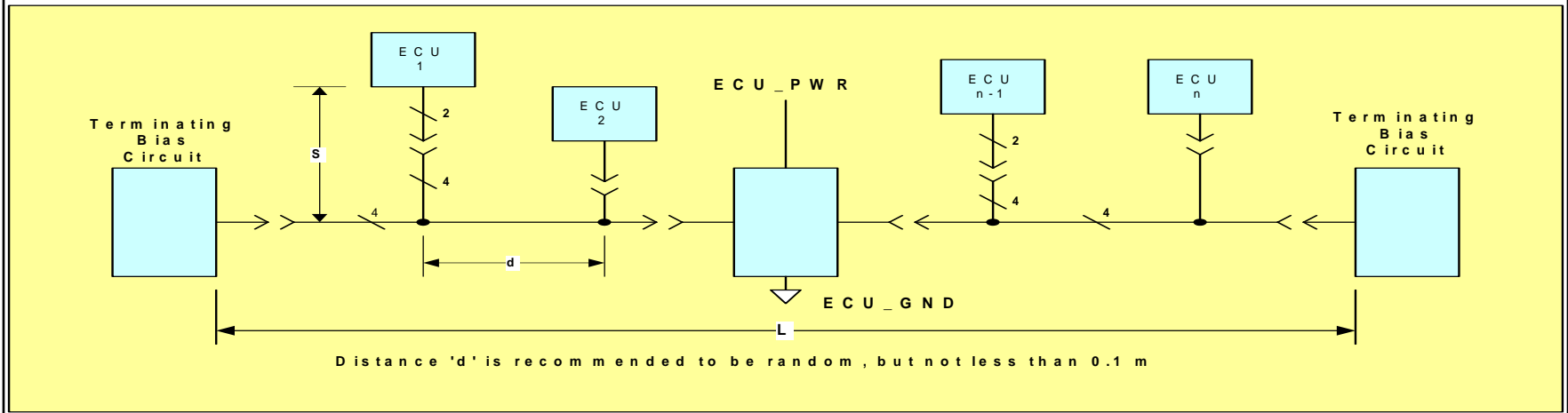

ISOBUS – A Brief Review

What is the ISO 11783 Standard?

✓ Physical Characteristics

Diagnostic Connector

- Pin A ECU_GND (-)
- Pin B ECU_PWR (+) un-switched
- with unconditioned 10 amp fuse
- Pin C Tractor Bus CAN_H
- Pin D Tractor Bus CAN_L
- Pin E Not Specified
- Pin F Not Specified
- Pin G Not Specified
- Pin H Implement Bus CAN_H
- Pin J Implement Bus CAN_L

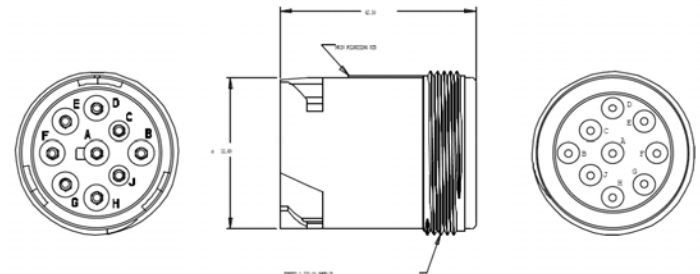

ISOBUS – A Brief Review

What is the ISO 11783 Standard?

✓ Physical Characteristics Bus Extension Connector

- Pin 1 TBC_PWR
- Pin 2 CAN_H
- Pin 3 TBC_RTN
- Pin 4 CAN_L



Challenges and Benefits of ISO11783 Standardization

ISOBUS – A Brief Review

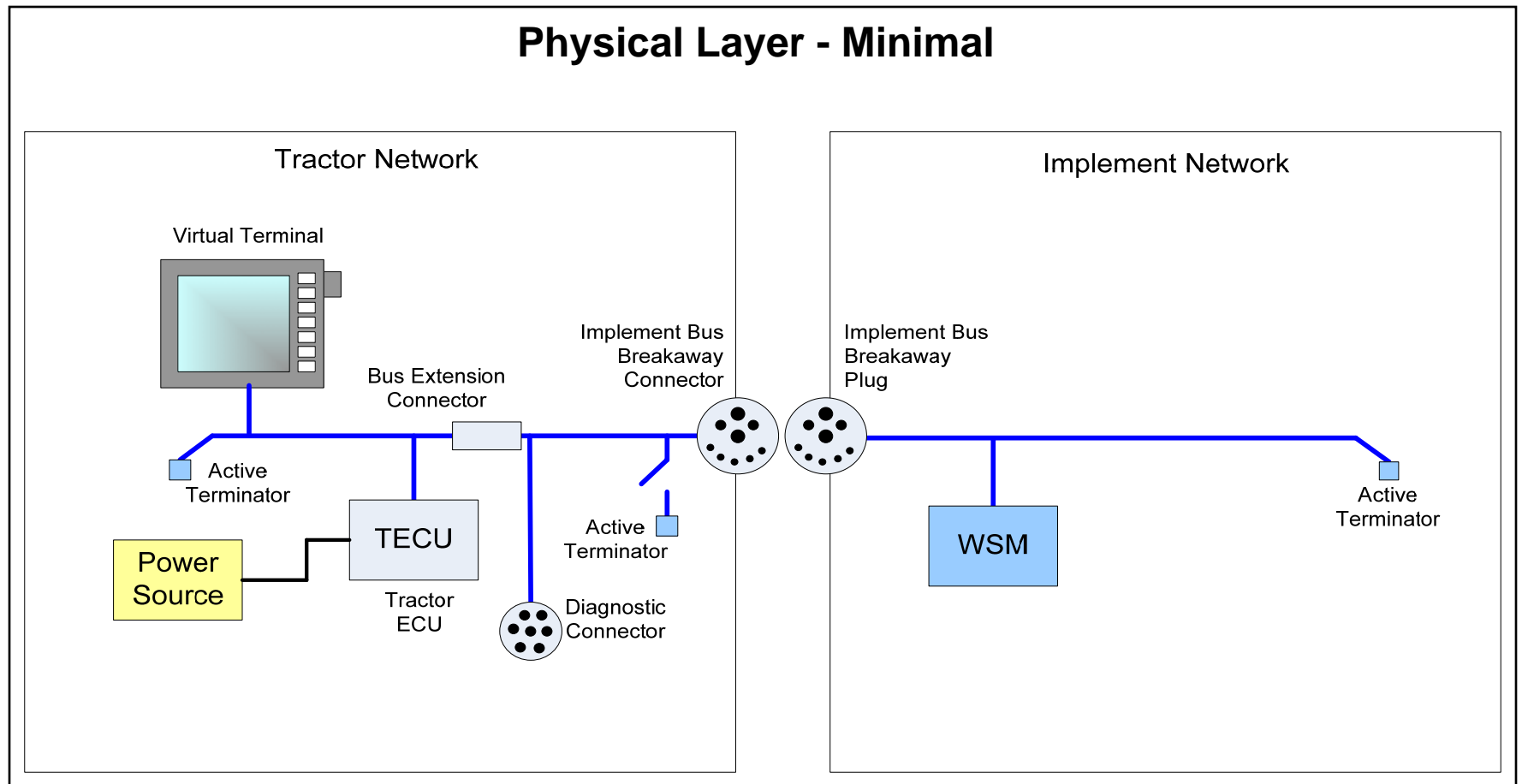

Challenges and Benefits of ISO11783 Standardization

ISOBUS – A Brief Review

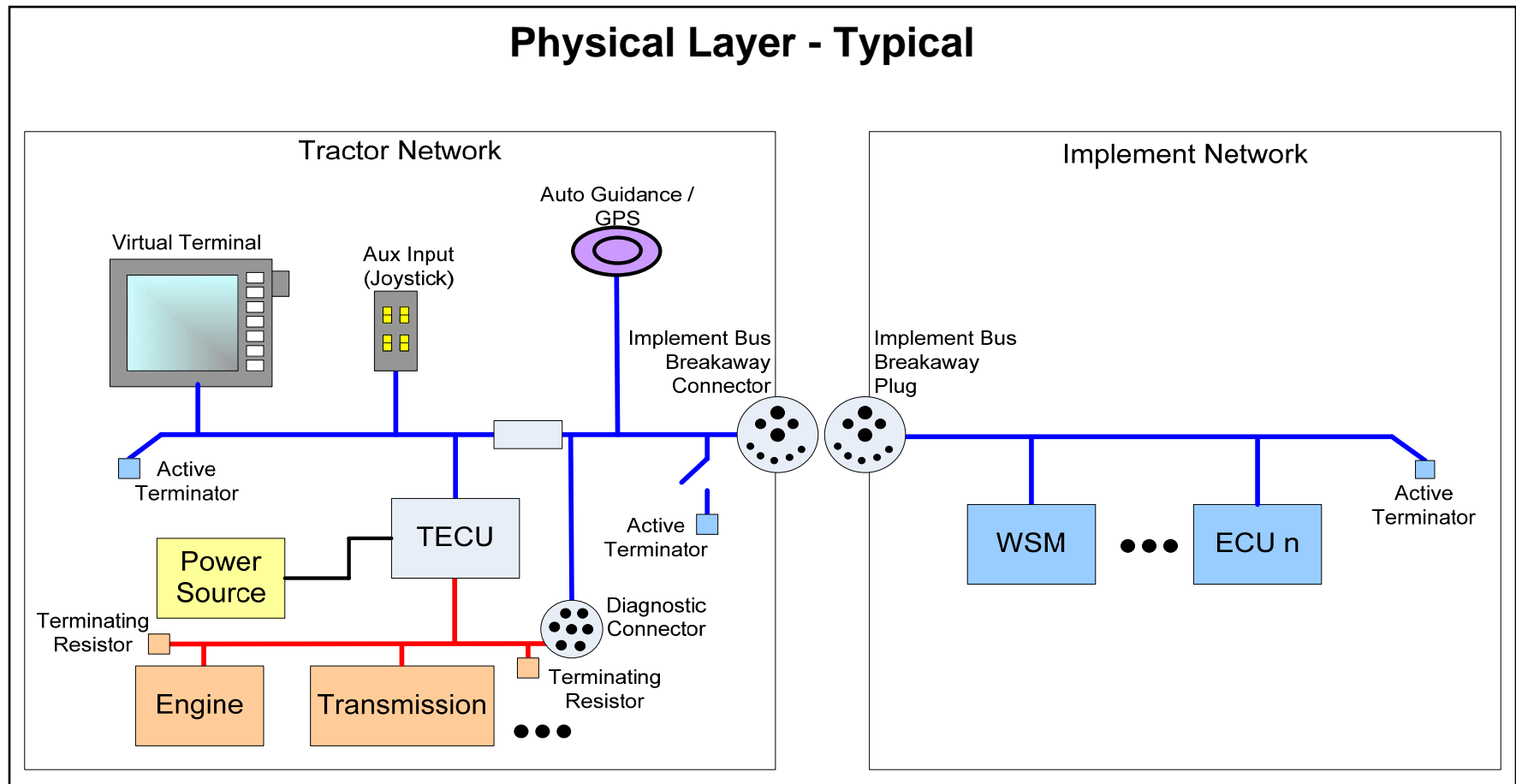

ISOBUS – A Brief Review

What does it take to have an ISOBUS network?

- ✓ **Physical Layer**
 - **wiring**
 - **connector(s)**
 - > **implement breakaway**
 - > **bus extension**
 - > **diagnostic connector**
 - **terminating bias**
- ✓ **Data Link Layer message structure**
- ✓ **Network Management – Address Claim, NAME Message**
- ✓ **Specific ECUs**
 - **Virtual Terminal**
 - **Working Set Master**
 - **Tractor ECU**

ISOBUS – A Brief Review

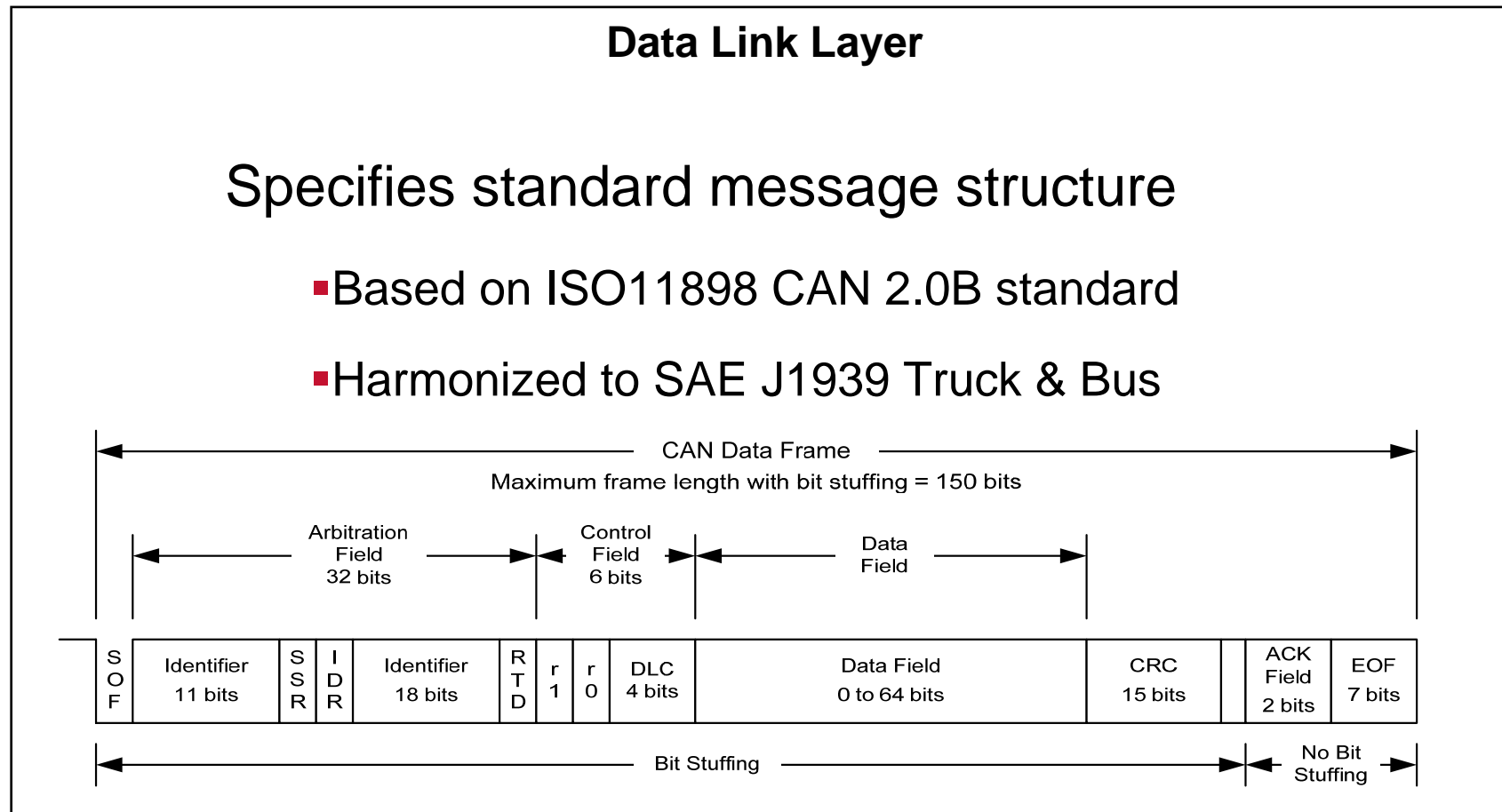

Challenges and Benefits of ISO11783 Standardization

ISOBUS – A Brief Review

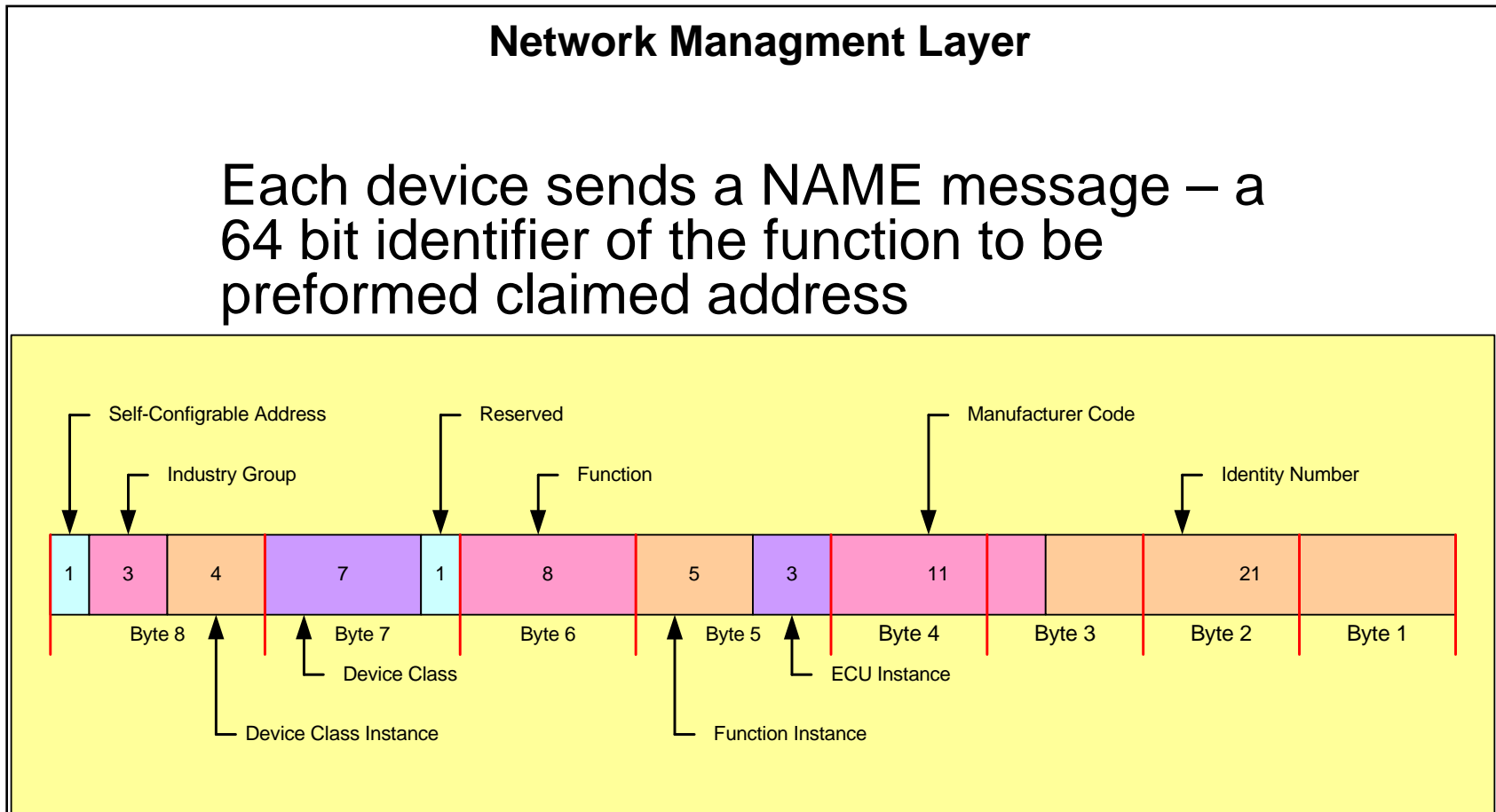

Topics

ISOBUS – A Brief Review

Benefits of ISO11783 Standardization

Potential Engineering Challenges

Next steps for ISO11783

Benefits of ISO 11783 Standardization

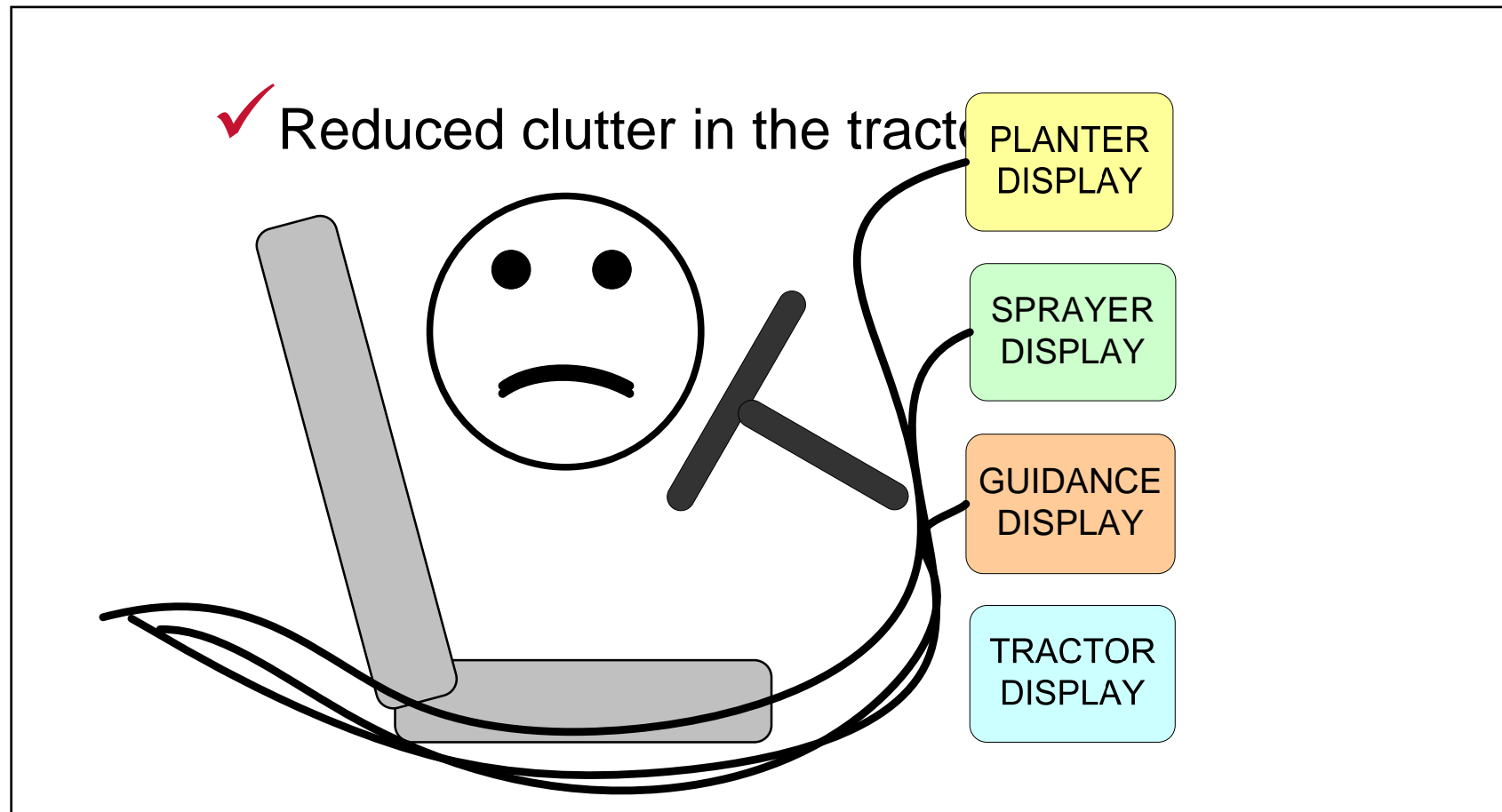

Benefits of ISO 11783 Standardization

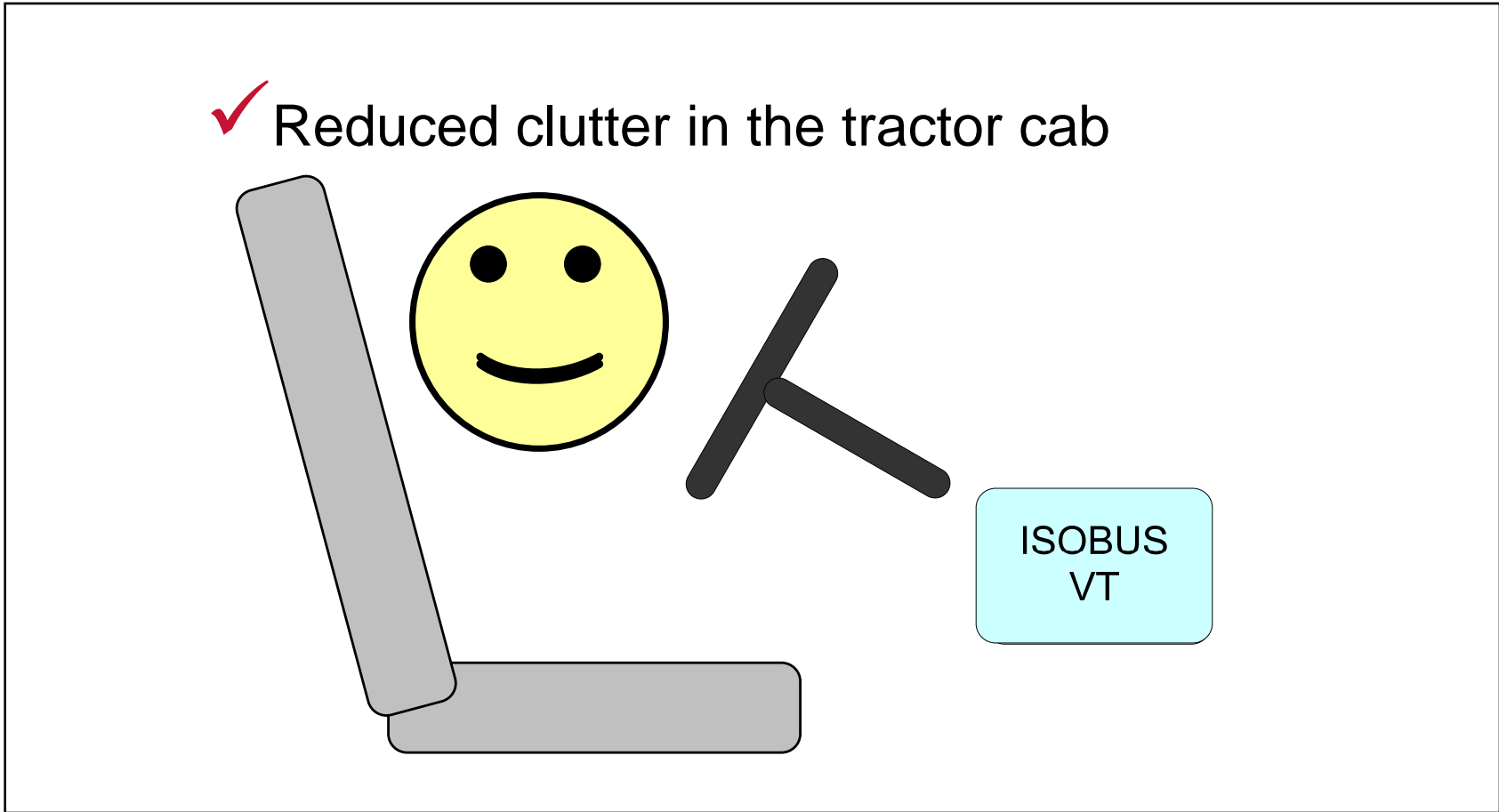

Challenges and Benefits of ISO11783 Standardization

Benefits of ISO 11783 Standardization

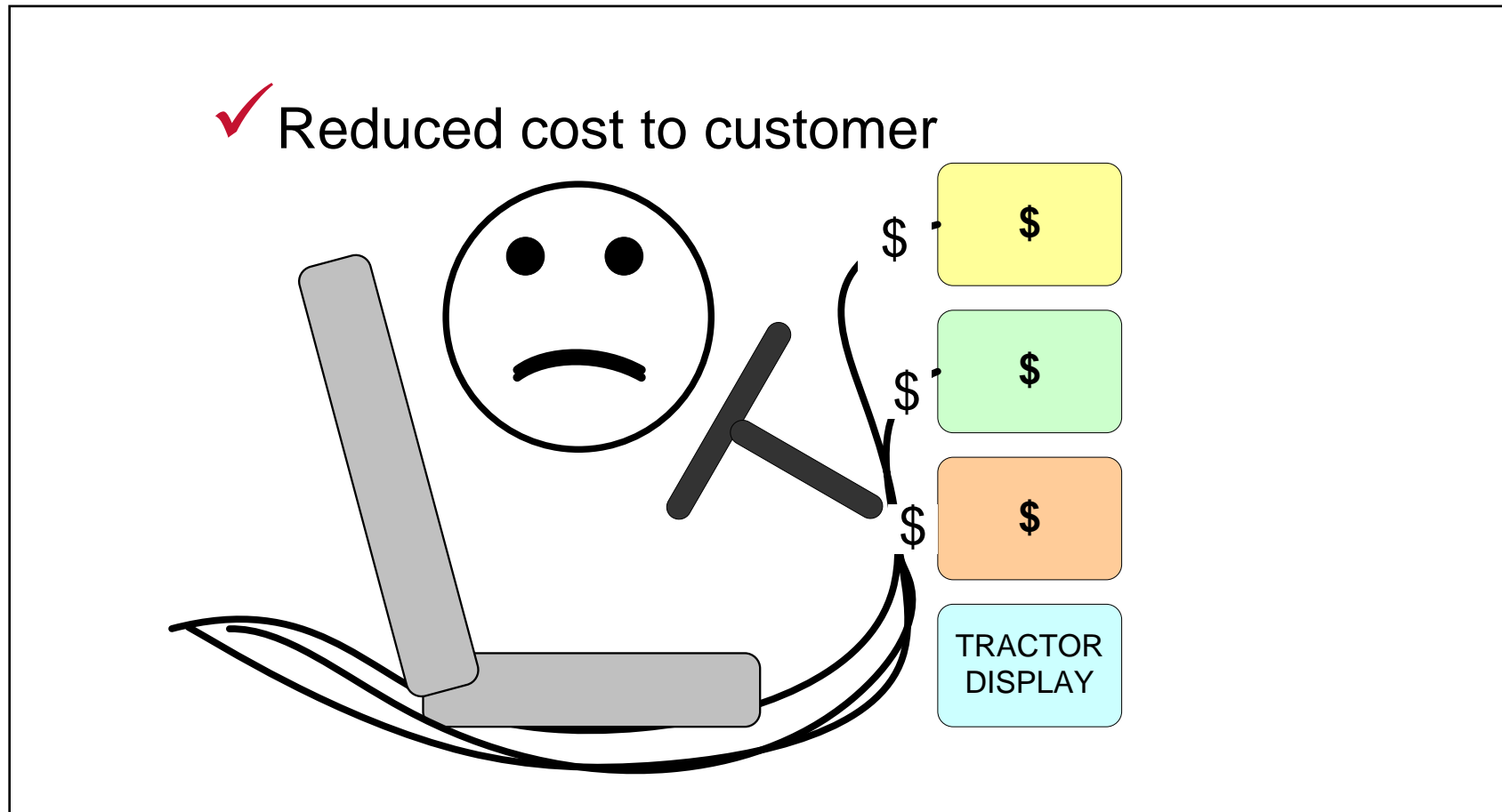

Challenges and Benefits of ISO11783 Standardization

Benefits of ISO 11783 Standardization

✓ Reduced cost to the customer

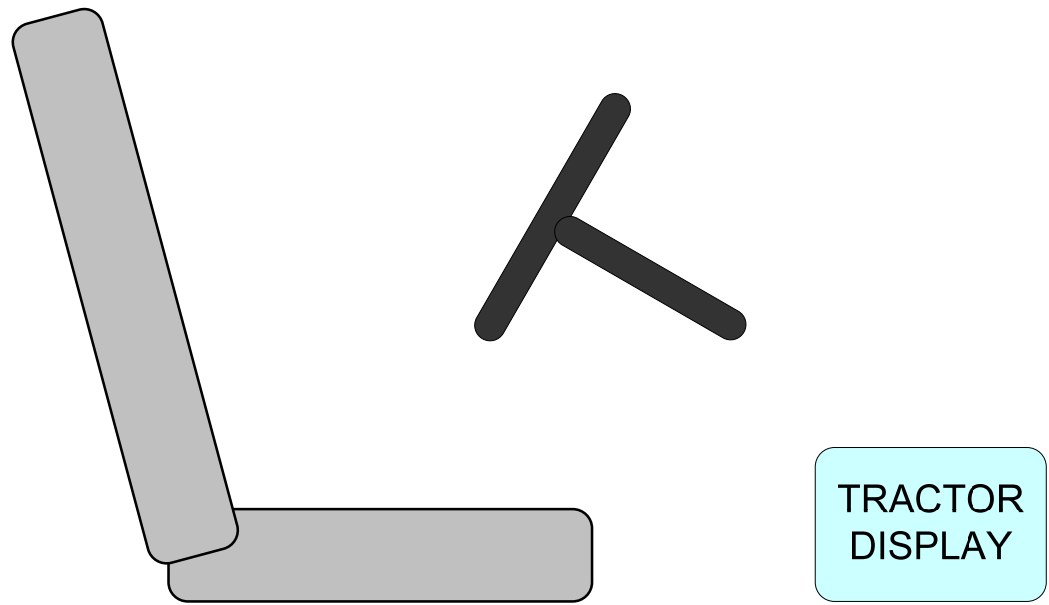

Benefits of ISO 11783 Standardization

✓ Reduced cost to the customer

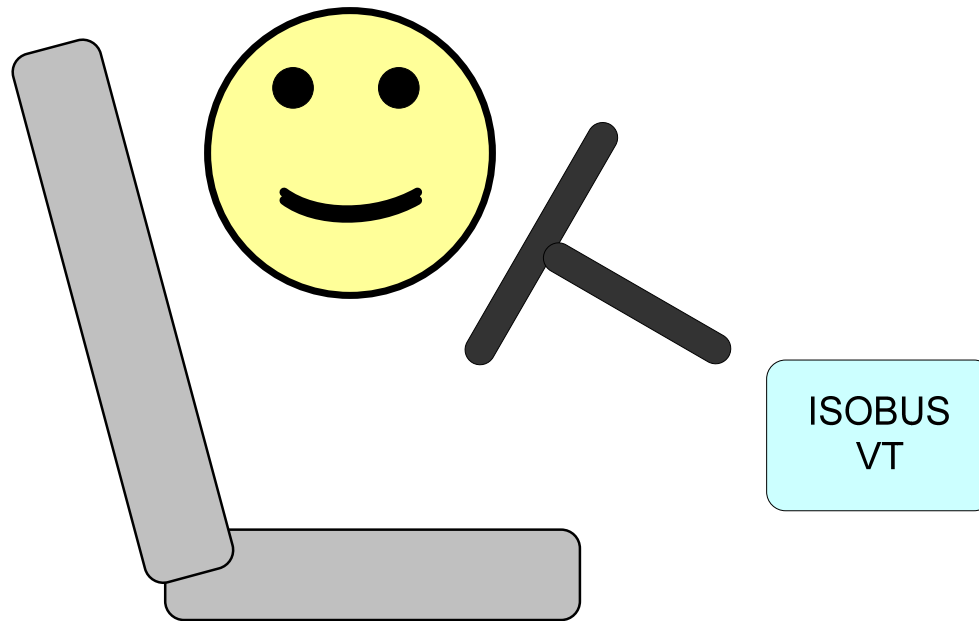

Benefits of ISO 11783 Standardization

✓ Reduced display development costs



COMBINE

PLANTER

**ROUND
BALER**

**SQUARE
BALER**

SPRAYER

Challenges and Benefits of ISO11783 Standardization

Benefits of ISO 11783 Standardization

✓ More customer choice

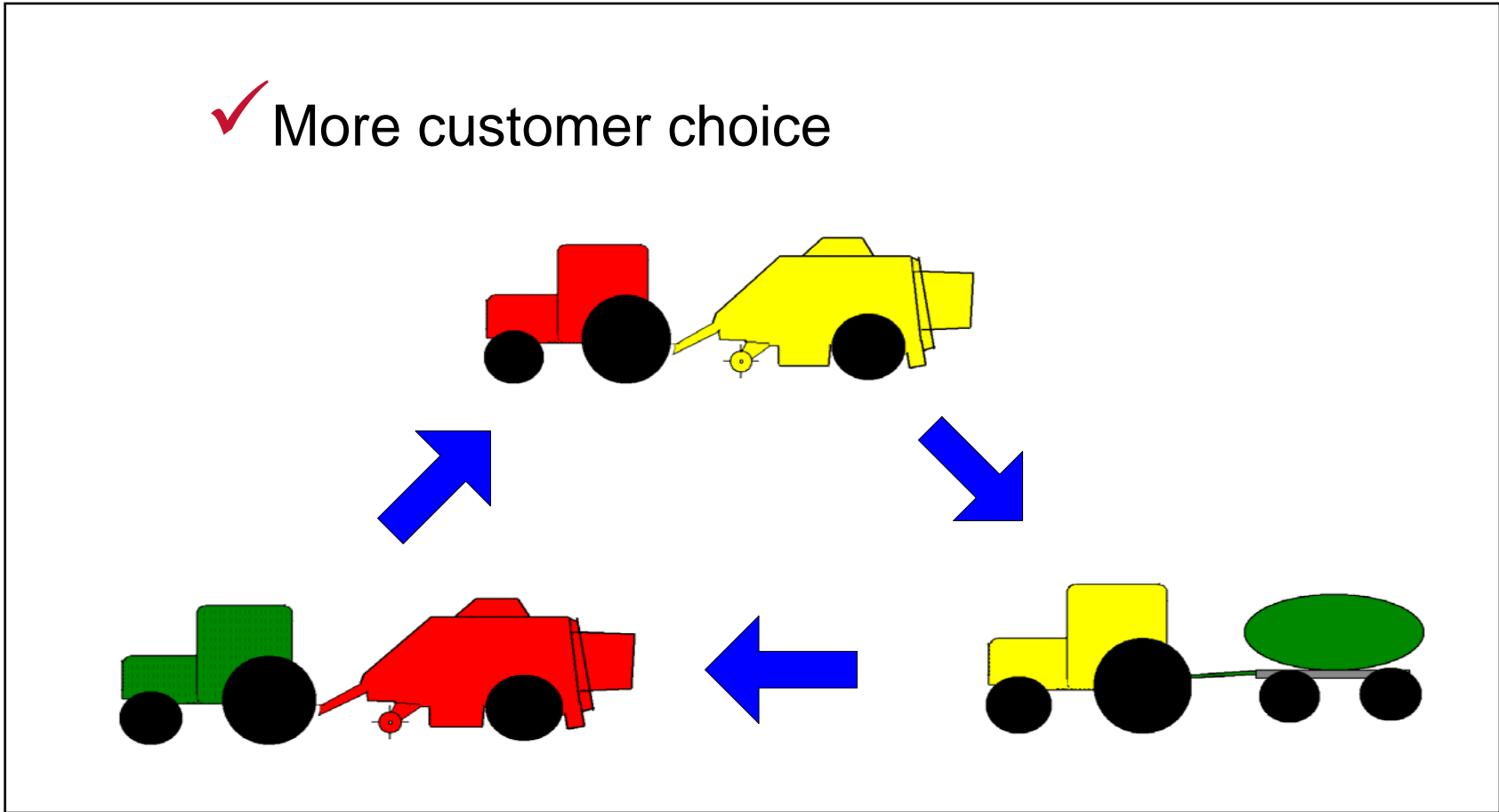





Benefits of ISO 11783 Standardization

- ✓ Added Functionality – Improved Diagnostics
 - ECUs must respond to CAN messages requesting a list of active and previous alarm conditions.
 - Promotes a framework for OEMs to provide better diagnostics of their electronic systems.

Benefits of ISO 11783 Standardization

- ✓ Added Functionality – Auxiliary Control
 - Mapping of implement control functions to tractor joystick

				 UP
				 DOWN
				 DEFAULT
				 DELETE
				 OK

Topics

ISOBUS – A Brief Review

Benefits of ISO11783 Standardization

Potential Engineering Challenges

Next steps for ISO11783

Potential Challenges

■ Technical Expertise

➤ Firmware developer

- C / C++
- Object Oriented Programming
- Embedded Software
- Control Theory
- Integer Math

➤ Networking

- Client / Server Communication
- Network Layer Methodology

➤ Electronic Engineering

- ECU Designer should be an Electrical Engineer
- Can be hired out – there are many ECU manufacturers

➤ ISO11783 Standard availability

- not available until published standard
- not available until published as standard

Potential Challenges

■ Design Expense

■ ISO VT Object Pool GUI Design Tools

- WTK Mask Generator ~\$2000 per copy + \$800 for upgrades
- IsoAgLib XML – Open Source \$0
- VT Designer- OSB Ag € 1,450 / year
- Some large manufacturers develop their own

Potential Challenges

- Design Expense (continued)
 - Compilers / Integrated Development Environments (IDE)
 - Microsoft Windows “Family” Platform
 - Microsoft Visual Studio .NET ~\$1,000 per license
Includes Cross Compilers for PDAs and Mobile Phones
 - Linux Platform
 - Monta Vista Linux ~\$10,000 per license
 - Linux KDE KDevelop / QMake – Open Source \$0

Potential Challenges

■ Design Expense (continued)

■ Embedded ECUs (No O/S or simple

- O/S)

- Tasking EDE ~\$2,000 per license

- Keil ~\$2,000 per license

■ Debugging

- CrossView TASKING's debugger

- Lauterbach EPROM Simulator –
needs special \$15,000 board on CPU

- Linux KDeBUG

- GNU Project Debugger (GDB)

- Microsoft .NET

Potential Challenges

- Design Expense (continued)
 - ISO 11783 Specification
 - Available from ISO website
 - Cost is ~\$3 per page with around 1000 pages for the entire ISO-11783 specification

Potential Challenges

- Marketing / Support
 - Training service technicians in CAN bus troubleshooting techniques
 - Training marketing and sales staff on for what ISOBUS can and can not do.
 - Who does the customer call if there is a problem with a system comprised of two or more manufactures?

Potential Challenges

- Marketing / Support
 - Training service technicians in CAN bus troubleshooting techniques
 - Training marketing and sales staff on for what ISOBUS can and can not do.
 - Who does the customer call if there is a problem with a system comprised of two or more manufactures?

Topics

ISOBUS – A Brief Review

Benefits of ISO11783 Standardization

Potential Engineering Challenges

Next steps for ISO11783

Next Steps for ISO 11783

- **In 2009, ISO plans to publish:**
 - **Part 10 – Task Controller,**
 - **Part 14 – Sequence Control**
 - **Part 6 2nd Edition – Virtual Terminal**

Challenges and Benefits of ISO11783 Standardization

Next Steps for ISO 11783

Agricultural Industry Electronics Foundation (AEF)



Der neue Standard für die Landwirtschaft
The new standard for agriculture

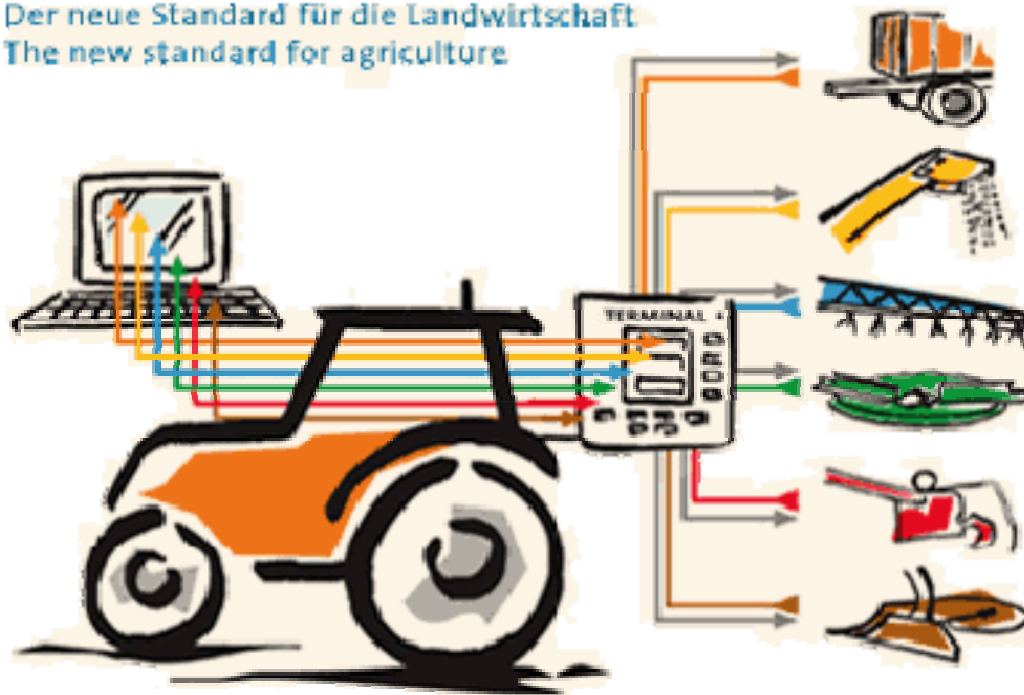

Challenges and Benefits of ISO11783 Standardization

Next Steps for ISO 11783

AEF may eventually replace voluntary industry organizations such as IGI (sponsored by VDMA) in Europe and NAITF (sponsored by AEM) in North America

Some important work ahead for AEF:

- ✓ Automated compliance test software
- ✓ Sponsoring industry plugfest (formally handled by NAITF and IGI)
- ✓ Integrating ISO 25119 safety standard as it progresses through ISO approval
- ✓ Promoting education and marketing of ISOBUS



Questions?